

Serial No.:

Year made:



WTBF 40/85-STB Bag Filter Housing

Wolftechnik Filtersysteme GmbH

Malsheimer Straße 67

71263 Weil der Stadt

Tel: (07033)7014-0

Fax: (07033)7014-20

eMail: vertrieb@wolftechnik.de

Internet: www.wolftechnik.de

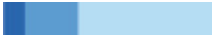

Index

1. Description	page 2
2. Technical specification	page 3
3. Safety instructions	page 4
4. Installation	page 5
5. Operation	page 6
6. Filter exchange	page 7/8
7. Maintenance	page 9
8. Spare parts	page 10
9. CE-Declaration of Conformity	page 11

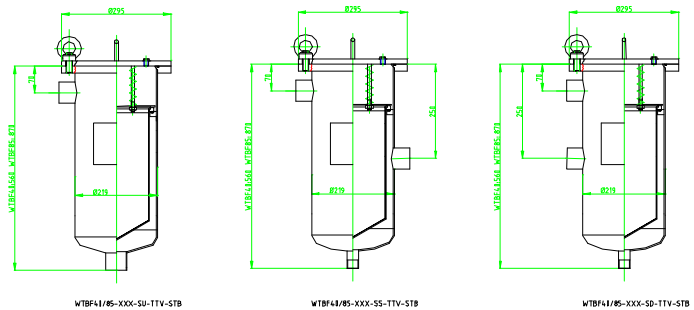

1. Description

WTBF Bag Filter Housings are made of stainless steel and are manufactured in three different ranges and four different sizes . They differentiate in their type of cover and in their filter area. The cover can be closed either by a V-clamp, by stud bolts or by swinging bolts. The four sizes stretch from 0.05 m² filter area at the smallest version up to 0.5 m² filter area at the largest version.

The following descriptions refer to the versions WTBF40-STB and WTBF85-STB with stud bolts and removable cover.

All WTBF Bag Filter Housings are supplied with a basket made of stainless steel mesh and with a compression device. One important feature of the WTBF Bag Filter Housings is, that the position, type and size of the inlet and outlet connections is not prescribed and can be manufactured according to the existing pipe lines or according to other special needs. As spare parts for all versions a pedestal and a volume reducer can be delivered.

- 2. Technical Specification**
- Material:** Housing: stainless steel 1.4571
Basket: stainless steel 1.4401
Gaskets: Viton, Viton-FEP-encapsulated
- Inlet / Outlet:** Size, type and position according customers specificati
- Vent:** ¼" female
- Drain:** 1" male (not for versions with connection "SU")
- Filter bags:** see table
- Internal parts:** stainless steel 1.4571
- Differetial pressure:** max. 3.5 bar
- Pressure:** max. 10 bar
- Temperature:** max. 95°C (sterilisation 150°C)
with PP filter bags max. 70°C
relating to bag material

Bag Filter Housing	WTBF40-STB	WTBF85-STB
Filter area	0.25 m ²	0.5 m ²
Filter bag	size 1	size 2
Volume reducer	+	+
Pedestal	+	+

Filter Bag	Size 1	Size 2
Filter area	0.25 m ²	0.5 m ²
Bag Filter Housing	WTBF40	WTBF85
Ø bag [mm]	180	180
Length [mm]	419	813
Volume bag [l]	8	17



3. Safety Instructions

Fundamental and important instructions for your safety:

WTBF Bag Filter Housings are determined for the filtration of liquids. Especially WTBF Bag Filter Housings should not be used for:



- Liquids whose chemical resistance against the used materials is not guaranteed.
- Liquids whose operation temperature is exceeding the maximum operation temperature shown in the technical specification.
- Liquids whose operation pressure is exceeding the maximum operation pressure shown in the technical specification.

A different use or use over it has to be considered as not to be made under the arrangements. For damages resulting out of this the manufacturer does not accept the responsibility.

If you have to carry out maintenance services or repairs please notice the following instructions:



- The filter housing is a pressure vessel and can be under pressure.
- Before opening the filter housing please make sure, that the vessel is not under pressure and that all inlet and outlet lines to the vessel are closed.
- Protect all inlet and outlet lines against unintentional or unauthorised opening.
- When opening the housing take notice of all instructions which have to be observed when handling the hauling product (e.g. protection clothes, no smoking...).
- Before restart of operation make sure, that all mechanical and other protection instruments are mounted tidy and that the vessel is closed orderly.

4. Installation

The filter housing has to be installed in a standing position, so that the pipe connections for inlet and outlet are located horizontal and the cover with the ring nuts is at the top.

The upper connection is the inlet, the lower connection is the outlet.

The inlet line has to be connected to the inlet, the outlet line to the outlet. For tight sealing we recommend a PTFE sealing tape or a sealing paste suitable for medium and application. The versions with flanged connections have to be installed with a gasket suitable for pressure temperature and medium.

For controlling and monitoring the filter pressure drop for filter bag exchange it is recommended to install pressure gauges and shut off valves in front of and behind the filter housing. For draining the filter housing the drain plugs can be replaced by suitable ball valves. The vent plugs of the housing can also be replaced by suitable ball valves.

WTBF Bag Filter Housings are delivered without filter bags!

The selection of the filter bag depends on the application and a precise specification can not be made in advance.

The first equipment and exchange of the filter bag should only be made with filter bags recommended by us, or with filter bags suitable for medium, pressure, temperature and application.

Installation of filter bag ==> see 6.) filter exchange

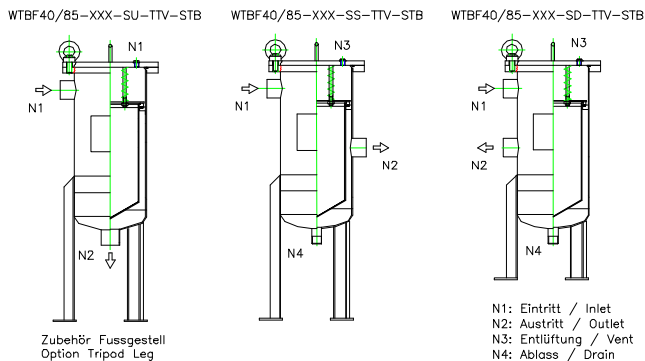

5. Operation

For start of operation and filter exchange proceed as follows:

- Open vent
- Slightly open outlet
- Slightly open inlet to fill up the vessel
- Close vent after filling
- The filter will be set under pressure now
- Check the filter housing for leakage
- In case of leakage close inlet and outlet again, open vent to discharge the pressure in the filter housing. Drain the liquid. Check the filter housing for damaged parts and replace them. Restart operation again.
- If there is no leakage when setting under pressure first the outlet and then the inlet can be opened completely.
- Slightly open and close the vent of the filter housing to release air out of the system if necessary.

Life time of the filter bag is depending on the application. Generally the exchange of the filter bag is recommended, if the maximum pressure drop of the filter bag is achieved. Generally the differential pressure for filter bag exchange is at 1.5 bar. In other cases the filter bag should be replaced at least once a year.

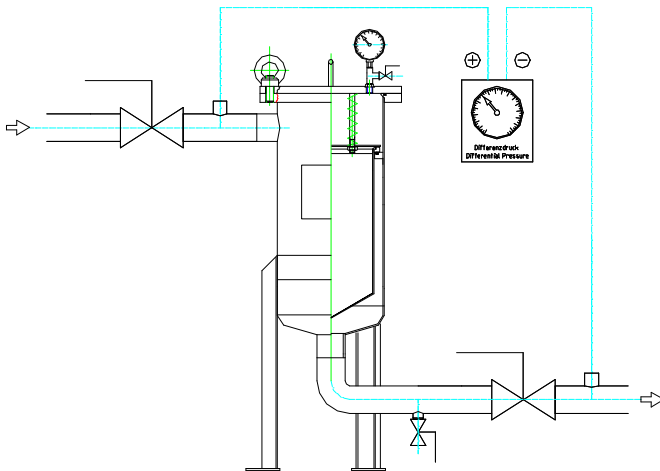

6. Filter exchange



If you have to replace the filter bag please take notice of the safety instructions on page 4 and as follows:

- The filter housing is a pressure vessel and can be under pressure.
- Before opening the filter housing please make sure, that the vessel is not under pressure and that all inlet and outlet lines to the vessel are closed.
- Protect all inlet and outlet lines against unintentional or unauthorised opening.
- When opening the housing take notice of all instructions which have to be observed when handling the hauling product (e.g. protection clothes, no smoking).
- Before restart of operation make sure, that all mechanical and other protection instruments are mounted tidy and that the vessel is closed orderly.

For change of filter bag please proceed as follows:

- Close inlet and outlet
- Slightly open vent
- The pressure will release now
- Open drain
- Open filter housing by removing the ring nuts. Lift the cover.
- Pull out the filter bag without the basket
- Clean housing and basket if necessary
- Check all parts, especially gaskets and sealing
- Place new filter bag in the basket and watch for correct sealing of the plastic collar ring in the basket.
- Close the cover with the compression plate by installing the ring nuts on the stud bolts
- Close drain
- Restart of operation ==> see 5.) Operation



1. Open housing



2. Pull out the filter bag



3. Place new filter bag in the basket



4. Close housing

7. Maintenance

During operation please take care of the following :

- max. operating pressure and max. operating temperature should not exceed.
- pressure shocks should be avoided.
- slightly open and close the vent to release air if necessary.
- max. differential pressure should not exceed and that the exchange of the filter bag takes place in time.
- no leakage is be found.
- the inspections are made according to the instructions.

If you have to carry out maintenance services or repairs please notice the following instructions:



- The filter housing is a pressure vessel and can be under pressure.
- Before opening the filter housing please make sure, that the vessel is not under pressure and that all inlet and outlet lines to the vessel are closed.
- Protect all inlet and outlet lines against unintentional or unauthorised opening.
- When opening the housing take notice of all instructions which have to be observed when handling the hauling product. (e.g. protection clothes, no smoking...).
- Before restart of operation make sure, that all mechanical and other protection instruments are mounted tidy and that the vessel is closed orderly.

Please always think about your safety and therefore respect the company safety instructions and the regulations of the government when carrying out maintenance services or repairs at the filter housing.

8. Spare parts

Pos.	Designation	Material	Order-Designation	Item-No.
1	Cover	1.4571	WTBF40/85-Deckel-STB	#999993
2	O-Ring for cover	Viton	WTBF40-ORVIT-GEH	#001082
		EPDM	WTBF40-OREPDM-GEH	#005672
		Silicone	WTBF40-ORSIL-GEH	#003856
		Buna	WTBF40-ORBUN-GEH	#001154
		FEP-encapsulat	WTBF40-ORFEP-GEH	#002252
		PTFE	WTBF40-ORPTFE-GEH	#001297
3	O-Ring for basket	Viton	WTBF40-ORVIT-KRB	#001075
		EPDM	WTBF40-OREPDM-KRB	#005673
		Silicone	WTBF40-ORSIL-KRB	#003857
		Buna	WTBF40-ORBUN-KRB	#001145
		FEP-encapsulat	WTBF40-ORFEP-KRB	#002253
		PTFE	WTBF40-ORPTFE-KRB	#001298
4	Basket	1.4401	WTBF40-KORB-GEWE	#001346
			WTBF85-KORB-GEWE	#001345
5	Ring nut M16	C15	WTBF40-Ringmutter	#999997
6	Washer d17	A2	WTBF40-U-Scheibe	#999997
7	Plug ¼"	1.4571	3WT-ESTOP-1/4-T	#007151
8	Compression spring	1.4571	WTBF40-Andrückfeder	#999993
9	Compression plate	1.4571	WTBF40-Andrückplatte	#999993
10	Nut	1.4571	WTBF40-Kontermutter	#999997

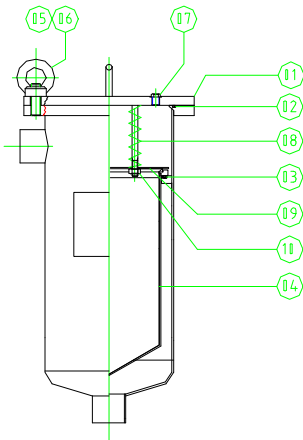

8. CE-Declaration of Conformity

Declaration of Conformity

According to Annex II of Directive 97/23/EC

We,

Wolftechnik Filtersysteme GmbH
Malmsheimerstraße 67
71263 Weil der Stadt

declare that our product

Bag Filter Housing
WTBF40/85-STB

to which this declaration is referring to, is in compliance
with the directive 97/23/EG and was subjected to the
following conformity assessment procedure

Module A

The monitoring is performed by

TÜV SÜDWEST, CE-0036
OR
TÜV HESSEN, CE-0091

Weil der Stadt

(Name, Signature)



Wolftechnik Filtersysteme GmbH